

of the side chains, (c) deviations from planes in the cluster (Å), (d) angles between planes in the cluster (deg); Table 3, oxygen-sodium-oxygen angles; Table 4, distances and angles in the tetrabutylammonium cation; Table 5, shortest contacts around sulfur atoms; Table 6, dimensions of *N*-methylpyrrolidone molecules, (a) distances and angles, (b) deviations from planes in Å; Table 7, some general distances in the structure (13 pages). Ordering information is given on any current masthead page.

References and Notes

- (1) The Institute for Cancer Research.
- (2) The University of California.
- (3) The asterisk after a sulfur atom, S, is used for atoms in the cube of a cluster, in order to differentiate them from external sulfur atoms. Abbreviations: DMF = dimethylformamide; HiPIP = high potential iron protein; SHE = standard hydrogen electrode; SCE = standard calomel electrode.
- (4) W. H. Orme-Johnson, *Annu. Rev. Biochem.*, **42**, 159-204 (1973).
- (5) E. T. Adman, L. C. Sieker, and L. H. Jensen, *J. Biol. Chem.*, **248**, 3987-3996 (1973).
- (6) C. W. Carter, Jr., J. Kraut, S. T. Freer, N. Xuong, R. A. Alden, and R. G. Bartsch, *J. Biol. Chem.*, **249**, 4213-4225 (1974).
- (7) T. Herskovitz, B. A. Averill, R. H. Holm, J. A. Ibers, W. D. Phillips, and J. F. Weiher, *Proc. Natl. Acad. Sci. U.S.A.*, **69**, 2437-2441 (1972).
- (8) B. A. Averill, T. Herskovitz, R. H. Holm, and J. A. Ibers, *J. Am. Chem. Soc.*, **95**, 3523-3534 (1973).
- (9) L. Que, Jr., M. A. Bobrik, J. A. Ibers, and R. H. Holm, *J. Am. Chem. Soc.*, **96**, 4168-4178 (1974).
- (10) C. W. Carter, Jr., J. Kraut, S. T. Freer, R. A. Alden, L. C. Sieker, E. Adman, and L. H. Jensen, *Proc. Natl. Acad. Sci. U.S.A.*, **69**, 3526-3529 (1972).
- (11) R. C. Job and T. C. Bruice, *Proc. Natl. Acad. Sci. U.S.A.*, **72**, 2478-2482 (1975).
- (12) D. F. Shriver, "The Manipulation of Air Sensitive Compounds", McGraw-Hill, New York, N.Y., 1969.
- (13) Too rapid addition gives a khaki solution which apparently contains complex with carboxylate groups attached directly to the iron.
- (14) The spectrum of the freshly dissolved sample has the general characteristics of previously reported analogues³¹ with maxima near 300 and 400 nm but with significantly broader peaks in aqueous solution with added mercaptide than observed for the other analogues in different solvents.

- As the slow hydrolysis progresses, the absorbance increases at all wavelengths.
- (15) A. C. T. North, D. C. Phillips, and F. S. Mathews, *Acta Crystallogr., Sect. A*, **24**, 351-359 (1968).
 - (16) O. Kennard, D. G. Watson, F. H. Allen, and S. M. Weeds, Ed., "Molecular Structures and Dimensions. Bibliography, 1974-75," Vol. 7, Bohn, Scheltema and Holkema, Utrecht, 1976, p 393.
 - (17) P. K. Gantzel, R. A. Sparks, R. E. Long, and K. N. Trueblood, UCLALS4 (1969) Program in Fortran IV. Modified by H. L. Carrell.
 - (18) "International Tables for X-Ray Crystallography", Vol. III. Kynoch Press, Birmingham, 1962, p 201.
 - (19) R. F. Stewart, E. R. Davidson, and W. T. Simpson, *J. Chem. Phys.*, **42**, 3175-3187 (1965).
 - (20) H. J. Bernstein, L. C. Andrews, H. M. Berman, F. C. Bernstein, G. H. Campbell, H. L. Carrell, H. B. Chiang, W. C. Hamilton, D. D. Jones, D. Klunk, T. F. Koetzle, E. F. Meyer, C. N. Morimoto, S. S. Sevier, R. K. Stodola, M. M. Strongson, and T. V. Willoughby, Second Annual AEC Scientific Computer Information Exchange Meetings. Proceedings of the Technical Program, 148-158 (1974).
 - (21) J. J. Mayerle, S. E. Denmark, B. V. DePamphilis, J. A. Ibers, and R. H. Holm, *J. Am. Chem. Soc.*, **97**, 1032-1045 (1975).
 - (22) L. Que, Jr., R. H. Holm, and L. E. Mortenson, *J. Am. Chem. Soc.*, **97**, 463-464 (1975).
 - (23) S. T. Freer, R. A. Alden, C. W. Carter, Jr., and J. Kraut, *J. Biol. Chem.*, **250**, 46-54 (1975).
 - (24) C. W. Carter, Jr., J. Kraut, S. T. Freer, and R. A. Alden, *J. Biol. Chem.*, **249**, 6339-6346 (1974).
 - (25) C. Y. Yang, K. H. Johnson, R. H. Holm, and J. G. Norman, Jr., *J. Am. Chem. Soc.*, **97**, 6596-6598 (1975).
 - (26) D. H. Templeton, *Acta Crystallogr.*, **13**, 685 (1960).
 - (27) F. A. Cotton, B. A. Frenz, R. R. Stults, and T. R. Webb, *J. Am. Chem. Soc.*, **98**, 2768-2773 (1976).
 - (28) L. Dupont, O. Dideberg, and A. Welter, *Acta Crystallogr., Sect. B*, **31**, 1018-1022 (1975).
 - (29) L. H. Jensen, L. C. Sieker, K. D. Watenpugh, E. T. Adman, and J. R. Herriott, *Biochem. Soc. Trans.*, **1**, 27-29 (1973).
 - (30) B. Ke, *Bioelectrochem. Bioenerg.*, **2**, 93-105 (1975).
 - (31) B. V. DePamphilis, B. A. Averill, T. Herskovitz, L. Que, and R. H. Holm, *J. Amer. Chem. Soc.*, **96**, 4159-4167 (1974).
 - (32) G. N. Schrauzer, G. W. Kiefer, K. Tano, and P. A. Doemeny, *J. Am. Chem. Soc.*, **96**, 641-652 (1974).
 - (33) T. C. Bruice, R. Maskiewicz, and R. Job, *Proc. Natl. Acad. Sci. U.S.A.*, **72**, 231-234 (1975).
 - (34) J. P. Danefy and C. J. Noel, *J. Am. Chem. Soc.*, **82**, 2511-2515 (1960).

Nucleophilic Substitution Reactions of Pentafluorosulfur and Tetrafluoro(trifluoromethyl)sulfur Halides

Tomoya Kitazume and Jean'ne M. Shreeve*

Contribution from the Department of Chemistry, University of Idaho, Moscow, Idaho 83843. Received November 9, 1976

Abstract: Pentafluorosulfur halides [SF₅X (X = Cl, Br)] form R₂NSF₄X (R = CH₃) at -78 °C with R₂NSi(CH₃)₃, while CF₃SF₄Cl undergoes defluorination and reduction to CF₃SCl(NR₂)₂ (R = CH₃, C₂H₅) at 25 or -78 °C. The latter compounds are hydrolyzed slowly to CF₃S(O)NR₂ and are oxidized easily to CF₃S(O)Cl(NR₂)₂ with *m*-chloroperbenzoic acid. Stepwise defluorination reactions of SF₅X (X = Cl, Br) and CF₃SF₄Cl with the reactive nucleophile LiN=C(CF₃)₂ result in the formation of the stable compounds, SF₃X[=NCF(CF₃)₂]₂, SFX[=NCF(CF₃)₂]₂, CF₃SF₂Cl[=NCF(CF₃)₂]₂, and CF₃SCl[=NCF(CF₃)₂]₂. With CH₃NH₂, CF₃SF₂Cl[=NCF(CF₃)₂]₂ forms the sulfur dimide, CF₃S(=NCH₃)₂[N=C(CF₃)₂].

The failure of sulfur hexafluoride to react with nucleophilic reagents has been recognized as due to kinetic rather than thermodynamic factors. Thus the free energy of hydrolysis is favorable ($\Delta G^\circ > -48 \text{ kcal mol}^{-1}$) although the compound is unaffected by boiling aqueous sodium hydroxide. Inertness is also displayed toward other nucleophiles such as the cyanide ion. This behavior contrasts sharply with the high reactivity toward nucleophiles which is shown by sulfur tetrafluoride in which the mean S-F bond energy (78 kcal mol⁻¹) is slightly higher than that in the hexafluoride. Fluorine exchange has also been observed in the tetrafluoride but not in the hexafluoride. The inertness of the sulfur (VI) compound is attributed to the fact that the highly symmetrical octahedral structure

is coordinatively saturated and lacks a point of attack for nucleophiles unless conditions are provided which bring about extreme electronic rearrangement.

In contrast to the hexafluoride, pentafluorosulfur chloride and pentafluorosulfur bromide undergo hydrolysis with aqueous alkali and the bromide is also attacked by water. Other pentafluorosulfur derivatives of the type SF₅X (X = CF₃, SF₅, OSF₅, etc.) are not attacked by alkali, however, and the suggestion has been made that the primary attack by nucleophiles in the case of SF₅Cl and SF₅Br is on the positive halogen.¹

Molecules such as SF₅CF₃, SF₅SF₅, and SF₅OSF₅ do not possess a well-defined positive center at which such attack can

occur. The idea that the halogen is positive in SF₅Cl and SF₅Br is supported by the greater ease of hydrolysis of SF₅Br compared with SF₅Cl and also by the observation that reaction with benzene under Friedel-Crafts conditions yields the halobenzene rather than C₆H₅SF₅. The anomalous position of SF₅Cl and SF₅Br is further illustrated by the ¹⁹F NMR data for a series of monosubstituted SF₆ derivatives.² The hexafluoride gives a single peak (ϕ -57.0), the chloro and bromo derivatives show shifts of ϕ -125.4 and -145.2, respectively, for the four equivalent fluorine atoms in the equatorial plane, whereas for all other known derivatives of the type SF₅X the value is in the range ϕ -36.5 to -72.1. This implies a major deshielding effect for the two halogen compounds, though no satisfactory explanation has yet been given. Shifts for the axial fluorine atoms in SF₅Cl and SF₅Br are normal and in the same range as for other monosubstituted derivatives.

It was against the background of this anomaly that the research described here was undertaken. Very little is known about the reactions of SF₅Cl and SF₅Br and the closely related species CF₃SF₄Cl with nucleophiles other than the OH⁻ ion and it was decided to investigate two reagents of different types, namely, R₂NSi(CH₃)₃ and LiN=C(CF₃)₂, in order to broaden the experimental basis for further discussion of this problem.

Results and Discussion

Dimethylaminotrimethylsilicon has been used frequently as a nucleophilic reagent in the field of sulfur-fluorine chemistry. Thus, for example, Glemser³ has shown that a single fluorine atom of OSF₄ is replaced by -NR₂ in reaction with R₂NSi(CH₃)₃ to form R₂NS(O)F₃. With (R₃Si)₃N at 70 °C, two fluorine atoms are replaced to form the sulfimide R₃Si-N=S(O)F₂. In its reaction with SF₅Cl and SF₅Br, which was first studied, (CH₃)₂NSi(CH₃)₃ was found at -78 °C to replace fluorine rather than chlorine or bromine to form (CH₃)₂NSF₄X (X = Cl, Br). At first sight this is surprising because the mean S-F bond energy is, ca. 76 kcal mol⁻¹, whereas the S-Cl bond is substantially weaker (ca. 46 kcal mol⁻¹). This difference is, however, offset by the greater energy of the Si-F bond (~139 kcal mol⁻¹) compared with ~93 kcal mol⁻¹ for the Si-Cl bond. Even with excess of reagent, substitution of further fluorine was not observed at this temperature. The ¹⁹F NMR spectra of the products, (CH₃)₂NSF₄Cl and (CH₃)₂NSF₄Br, show singlets at ϕ -105 and ϕ 129, respectively, which indicate that all of the fluorine atoms are equivalent and in the equatorial positions. A possible route to these trans products is shown below.

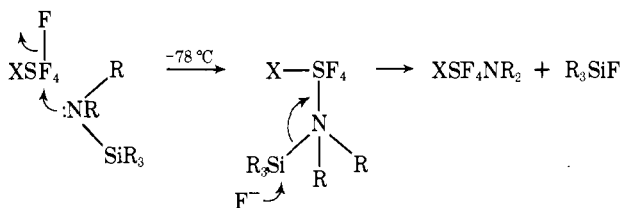

In the reaction of (CH₃)₂NSi(CH₃)₃ with SF₅Cl and SF₅Br at a higher temperature (25 °C) a series of experiments failed to give volatile products other than (CH₃)₃SiF, which was formed in quantities which suggest the formation of SCI[N(CH₃)₂]₃ or SBr[N(CH₃)₂]₃. Extraction of the tarry residues with a variety of solvents did not lead to the isolation of any sulfur-containing products. It appears that under these conditions further fluorine atoms are replaced rapidly by NR₂ groups but that the products are unstable.

The reaction of CF₃SF₄Cl with the dimethyl- and diethylaminosilicon compounds at 25 °C was examined next. A reduction of sulfur(VI) to sulfur(IV) was observed, the reaction being represented by the equation

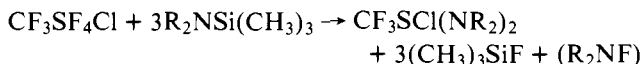

These compounds are colorless liquids which boil at 195 °C [N(CH₃)₂] and 206 °C [N(C₂H₅)₂] and which hydrolyze very slowly in water to form the sulfoxide CF₃S(O)NR₂. As in the case of SF₅Cl and SF₅Br, attack was at sulfur, with concomitant breaking of the S-F bonds, the S-Cl and S-Br bonds being unaffected. Four fluorines were displaced and the amount of (CH₃)₃SiF formed was 3 mol per mole of CF₃SF₄Cl. Although R₂NF is a likely, but unstable, product, it was not possible to isolate it or its decomposition products from the reaction mixture. Indeed, no specific oxidation product (or products) could be isolated from the tarry residue, though we attempted to find evidence for the presence of azo compounds, which Roberts suggested were produced in the reaction of SF₅Cl with aromatic amines.¹ In an attempt to moderate the reaction it was run at -78 °C under otherwise comparable conditions. The same sulfur(IV) derivative was, however, isolated and there was no evidence for the formation of a sulfur(VI) compound such as CF₃SF₃Cl(NR₂) which might be a reactive intermediate. The reaction scheme shown below accounts for the observed products.

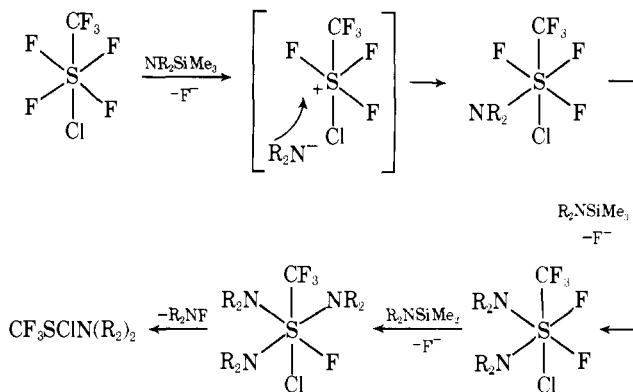

Although there are few examples of reactions of CF₃SF₄Cl with nucleophiles in the known cases, reduction of S(VI) to S(IV) does occur,⁴ e.g.,

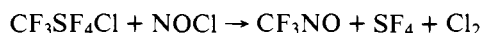
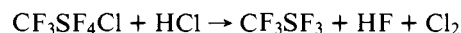

The sulfur(IV) compounds CF₃SCl(NR₂)₂ are readily oxidized by MCPBA to the sulfoxides CF₃S(O)Cl(NR₂)₂. These are stable colorless liquids which boil at 204 °C [N(CH₃)₂] and 213 °C [N(C₂H₅)₂]. This is a normal reaction of this reagent, other examples being:



The chlorine atom in CF₃SCl(NR₂)₂ was found to undergo very slow hydrolysis by water to yield CF₃S(O)(NR₂), one dialkylamino group being removed.

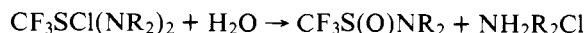

The mechanism of this reaction may involve two steps, in the first of which Cl is displaced by OH⁻, the second being fission of a single S-N bond (Scheme I). Reaction of CF₃SF₄Cl with the nucleophilic reagents NaOMe and methanol-trimethylamine was also studied and again resulted in the elimination of four fluorine atoms and products mainly of CF₃SO₂Cl, with trace amounts of CF₃SO₂F; i.e., there was no reduction to sulfur(IV) in this case.

Lithium hexafluoroisopropylideneimine, (CF₃)₂C=NLi, has been used as a reactive nucleophile by workers in this labora-

Scheme 1

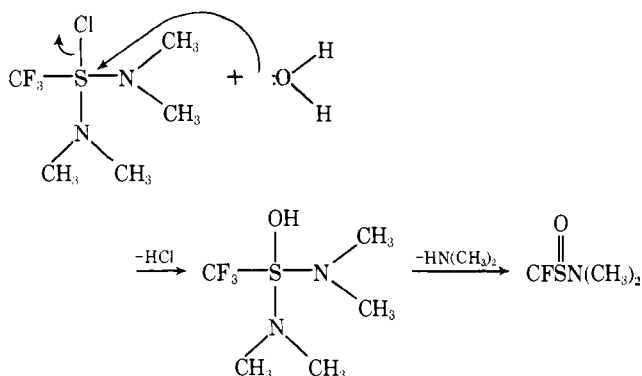

tory^{7,8} and elsewhere.⁹ For example, with SF₄ extensive rearrangement reactions⁷ occur

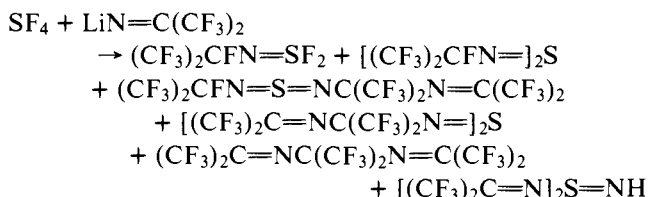

or with RPF₄⁹



The reactions of the nucleophile LiN=C(CF₃)₂ with SF₅Cl or SF₅Br occurred without reduction of S(VI) to S(IV) though in each instance the result was again breaking of S—F bonds, leaving S—Cl or S—Br bonds unchanged. Thus, there was a stepwise replacement in the case of SF₅X (X = Cl, Br), with concomitant fluoride ion migration:



I

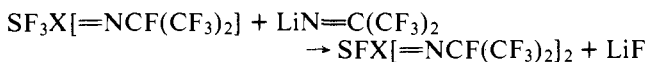

II

Both products (I and II) are formed if the ratio SF₅X:LiN=C(CF₃)₂ exceeds 1, but II is the sole product when the lithium compound is in excess. These reactions involve a fluoride ion migration from sulfur to a more electropositive center as is observed with the S(IV) and P(V) compounds referred to above. However, in contrast with the partially substituted derivative of SF₄,⁷ e.g., (CF₃)₂CFN=SF₂, or of CF₃SF₃, e.g., CF₃SF=NCF(CF₃)₂, which readily undergoes further nucleophilic attack by LiN=C(CF₃)₂ to displace all S—F bonds, the F and/or X atoms in SFX[=NCF(CF₃)₂]₂ react further with LiN=C(CF₃)₂ only slowly to give an unidentified involatile liquid. The larger lattice energy of LiF compared to LiCl or LiBr must contribute greatly to the breaking of S—F bonds and retention of the S—X (X = Cl, Br) bonds in these new molecules.

The reaction of CF₃SF₄Cl with LiN=C(CF₃)₂ follows a similar course with preferential breaking of the S—F bonds, leading successively to CF₃SF₂Cl[=NCF(CF₃)₂] and CF₃SCl[=NCF(CF₃)₂]₂. Both compounds were isolated and characterized, and it was shown further that CF₃SF₂Cl[=NCF(CF₃)₂] reacts normally with methylamine.

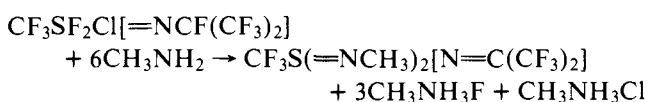

The ¹⁹F NMR data obtained for these new sulfur(VI) imides and diimides are very useful in establishing their structures. These are given below. In addition, the mass spectra of

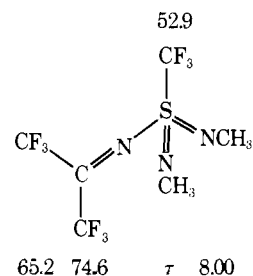
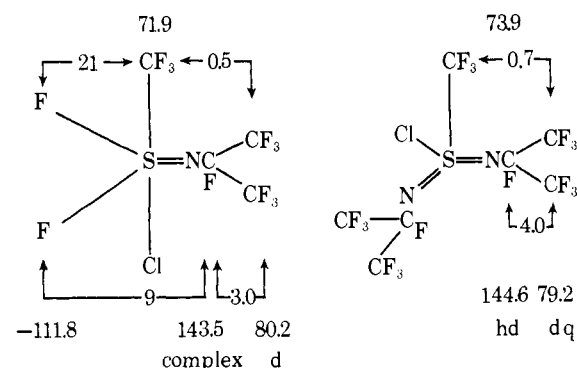
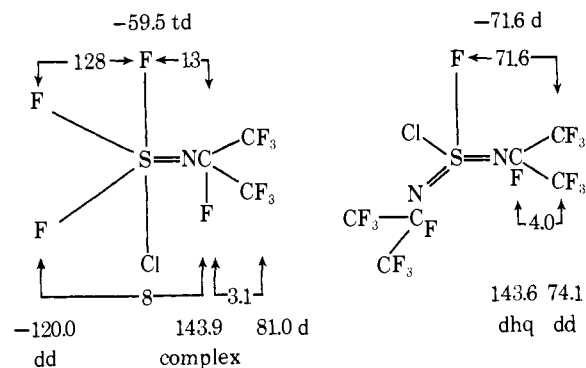

these compounds contain molecule ions for the Cl containing ones and (M—F)⁺ for those which contain Br, and appropriate isotope ratios. Possible routes to these compounds are shown in Scheme II. The chlorosulfur imides and diimides are colorless, water sensitive compounds which are stable at least to their boiling points in glass and the pale yellow bromosulfur imides and diimides behave similarly.

Conclusion

Reviewing these results as a whole, it is not surprising that the pentafluorosulfur group does undergo reactions with a variety of nucleophiles since it is well established that it is much less stable to defluorination than the trifluoromethyl group for example. This behavior for SF₅ has been observed frequently, e.g., SF₅Cl with PhLi¹ or with MePCl₂¹⁰ where defluorination and reduction to SF₄ or SCl₂ occurred. Although in photolytic reactions of SF₅X (X = Cl, Br) with olefins¹¹⁻¹⁹ or in addition to zero valent metal complexes,²⁰ the integrity of the SF₅-moiety is maintained, subsequent reactions of these products often involve defluorination of the sulfur group. However, in this work, we have found that the S—X (X ≠ F) bond is retained preferentially in reactions with two different nucleophiles. We have been able to isolate and characterize not only the reduced products obtained when CF₃SF₄Cl^{4,21,22} was reacted with R₂NSiR₃ but also the mono- and disubstituted derivatives of SF₅X (X = Cl, Br) and CF₃SF₄Cl produced with LiN=C(CF₃)₂.

Scheme II

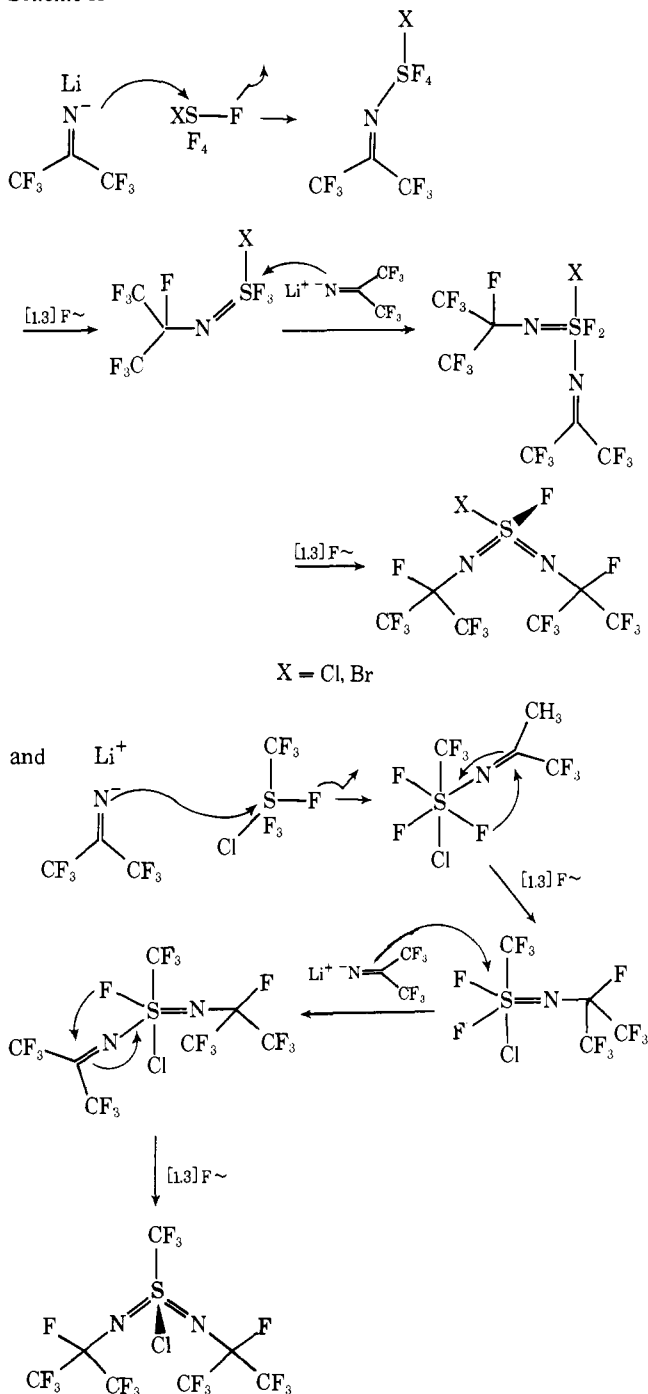

Further, our suggested mechanism for these reactions, which involves initial attack at the sulfur atom, seems to be a more plausible route than attack at chlorine since, for example, no $(CF_3)_2C=NC1$ is isolated from the reaction of SF_5Cl with $LiN=C(CF_3)_2$.

Experimental Section

Materials. Literature methods were used to prepare CF_3SF_4Cl ,⁴ SF_5Cl ,²³ SF_5Br ,²⁴ and $LiN=C(CF_3)_2$.⁸ Monomethylamine was used as received.

General Procedures. Gases and volatile liquids were handled in a conventional Pyrex vacuum apparatus equipped with a Heise-Bourdon tube gauge. Volatile starting materials and purified products were measured quantitatively by PVT techniques. Vapor-pressure studies were carried out by using an isothermometric method.

Infrared spectra were taken by using a Perkin-Elmer 457 spec-

trometer with a 5-cm gas cell fitted with KBr windows. The ^{19}F and 1H NMR spectra were obtained using a Varian HA-100 spectrometer with CCl_3F or $(CH_3)_4Si$ as an internal standard. Mass spectra were obtained using a Hitachi Perkin-Elmer RMU-6E spectrometer at 17 eV.

Preparation of $CF_3SCl[N(CH_3)_2]_2$. CF_3SF_4Cl (2 mmol) and $(CH_3)_2NSi(CH_3)_3$ (6 mmol) were condensed at $-196^\circ C$ into a Pyrex glass vessel equipped with a Teflon stopcock. The reaction mixture was warmed slowly to $25^\circ C$ and allowed to remain for 5 h. After trap-to-trap distillation, products identified were $CF_3SCl[N(CH_3)_2]_2$ (1.5 mmol) and $(CH_3)_3SiF$ (5.8 mmol). An unidentified solid residue remained in the reaction flask. $CF_3SCl[N(CH_3)_2]_2$ is a colorless liquid with a boiling point of $95^\circ C$ obtained from the equation $\log P_{Torr} = 7.12 - 1984/T$. The molar heat of vaporization is 9.1 kcal and the Trouton constant is 24.3 eu.

NMR: ^{19}F , ϕ 73.6 (CF_3); 1H , τ 8.00 (CH_3). The infrared spectrum is as follows: 2942 m, 2915 m, 1485 m, 1460 m, 1390 m, 1278 m, 1205–1145 vs, 1110 s, 947 s, 722 m, 685 ms, 588 m, 488 cm^{-1} w. Anal. Calcd for $C_5H_{12}N_2SiCF_3$: C, 26.73; H, 5.38; N, 12.47. Found: C, 26.51; H, 5.41; N, 12.52.

Preparation of $CF_3SCl[N(C_2H_5)_2]_2$. CF_3SF_4Cl (2 mmol) and $(CH_3)_3SiN(C_2H_5)_2$ (6 mmol) were condensed as in the reaction above and worked up similarly. Volatile compounds identified were $CF_3SCl[N(C_2H_5)_2]_2$ (1.6 mmol) and $(CH_3)_3SiF$ (5.76 mmol). $CF_3SCl[N(C_2H_5)_2]_2$ is a liquid with a boiling point of $206^\circ C$ from the equation $\log P_{Torr} = 7.20 - 2069/T$. The molar heat of vaporization is 9.5 kcal and the Trouton constant is 19.8 eu.

NMR: F, ϕ 77.6; 1H , τ 6.67 (CH_2 , q), 8.80 (CH_3 , t). The infrared spectrum is as follows: 2978 m, 2940 m, 1463 m, 1388 m, 1195–1145 vs, 1108 s, 1008 ms, 930 ms, 788 ms, 661 m, 590 w, 505 w, 470 cm^{-1} w.

Anal. Calcd for $C_9H_{20}N_2SiCF_3$: C, 38.50; H, 7.18; N, 9.98. Found: C, 38.27; H, 7.02; N, 10.08.

Preparation of $CF_3S(O)Cl[N(CH_3)_2]_2$. $CF_3SCl[N(CH_3)_2]_2$ (2 mmol) was reacted with *m*-chloroperbenzoic acid (3 mmol) at $0^\circ C$ for 24 h. After the trap-to-trap separation, $CF_3S(O)Cl[N(CH_3)_2]_2$ (0.6 mmol) was obtained. This compound is a colorless liquid having a boiling point of $204^\circ C$ from the equation $\log P_{Torr} = 7.35 - 2133/T$. The molar heat of vaporization is 9.6 kcal and the Trouton constant is 20.5 eu.

NMR: ^{19}F , ϕ 80.6; 1H , τ 7.68 (CH_3 , s). The infrared spectrum is as follows: 2970 m, 1440 w, 1385 w, 1220 s, 1189 s, 1128 ms, 1098 s, 768 s, 561 cm^{-1} w.

Anal. Calcd for $C_5H_{12}N_2SiOClF_3$: C, 24.95; H, 5.03; N, 11.64. Found: C, 24.87; H, 5.13; N, 11.57.

Preparation of $CF_3S(O)Cl[N(C_2H_5)_2]_2$. $CF_3SCl[N(C_2H_5)_2]_2$ (2 mmol) and *m*-chloroperbenzoic acid (3 mmol) were reacted at $0^\circ C$. After 24 h, $CF_3S(O)Cl[N(C_2H_5)_2]_2$ was obtained by distillation. It is a stable liquid with a boiling point of $213^\circ C$ from the equation $\log P_{Torr} = 7.63 - 2309/T$. The molar heat of vaporization is 10.6 kcal and the Trouton constant is 21.7 eu.

NMR: ^{19}F , ϕ 81.5; 1H , τ 6.68 (CH_2 , q), 8.84 (CH_3 , t). The infrared spectrum is as follows: 2961 m, 1260 s, 1213 ms, 1128 m, 1068 s, 952 ms, 848 s, 572 cm^{-1} w.

Anal. Calcd for $C_9H_{20}N_2SiOClF_3$: C, 36.42; H, 6.79; N, 9.44. Found: C, 36.39; H, 6.76; N, 9.38.

Hydrolysis of $CF_3SCl[N(CH_3)_2]_2$. $CF_3SCl[N(CH_3)_2]_2$ (2 mmol) was condensed on to excess H_2O at $-196^\circ C$ and warmed to $25^\circ C$. After 24 h the product was separated by trap-to-trap distillation and identified as $CF_3S(O)N(CH_3)_2$ (1.46 mmol) based on its infrared spectrum.²⁵

Reaction of CF_3SF_4Cl and $NaOCH_3$. CF_3SF_4Cl (2 mmol) was condensed onto $NaOCH_3$ (5 mmol) at $-196^\circ C$ and warmed slowly to $25^\circ C$. After 10 h, the products were separated by trap-to-trap distillation. Unreacted CF_3SF_4Cl (1.1 mmol) was recovered and CF_3SO_2Cl (0.62 mmol) (identified by its infrared spectrum)²⁶ was obtained.

Reaction of CF_3SF_4Cl and CH_3OH . CF_3SF_4Cl (1 mmol) and $(CH_3)_3N$ (4 mmol) were condensed onto CH_3OH (excess) and warmed to $25^\circ C$. After 10 h, pure CF_3SO_2Cl (0.75 mmol) was separated by trap-to-trap distillation and identified by its infrared spectrum.²⁶

Preparation of $(CH_3)_2NSF_4Cl$. SF_5Cl (3.5 mmol) and $(CH_3)_2NSi(CH_3)_3$ (3.0 mmol) were condensed together at $-196^\circ C$ and allowed to warm slowly to $-78^\circ C$ and remain at this temperature for 12 h. $(CH_3)_2NSF_4Cl$ (2.3 mmol) was obtained by trap-to-trap dis-

tillation. It is a liquid with a boiling point of 86 °C obtained from the equation $\log P_{\text{Torr}} = 8.10 - 1874/T$. The molar heat of vaporization is 8.6 kcal and the Trouton constant is 23.9 eu.

NMR: ^{19}F , $\phi -105$ (s); ^1H , $\tau 8.13$ (s). The infrared spectrum is as follows: 2962 ms, 1258 s, 1070 s, 908 w, 850 ms, 755 ms, 736 m, 547 w, 440 cm^{-1} w.

Anal. Calcd for $\text{C}_2\text{H}_6\text{NSClF}_4$: C, 12.81; H, 3.22; N, 7.47. Found: C, 12.75; H, 3.14; N, 7.31.

Preparation of $(\text{CH}_3)_2\text{NSF}_4\text{Br}$, SF_5Br (3.5 mmol) and $(\text{CH}_3)_2\text{NSi}(\text{CH}_3)_3$ (3 mmol) were condensed as above and after 12 h at -78 °C, the $(\text{CH}_3)_2\text{NSF}_4\text{Br}$ (2.1 mmol) was obtained by trap-to-trap distillation. This compound is a liquid having a boiling point of 99 °C from the equation $\log P_{\text{Torr}} = 8.21 - 1983/T$. The molar heat of vaporization is 9.1 kcal and the Trouton constant is 24.4 eu.

NMR: ^{19}F , $\phi -129$ (SF_4 , s); ^1H , $\tau 8.16$ (CH_3). The infrared spectrum is as follows: 2970 ms, 1251 s, 1081 s, 861 ms, 761 m, 740 m, 553 w, 437 cm^{-1} w.

Anal. Calcd for $\text{C}_2\text{H}_6\text{NSBrF}_4$: C, 10.35; H, 2.61; N, 6.04. Found: C, 10.52; H, 2.51; N, 6.28.

Preparation of $\text{CF}_3\text{SF}_2\text{Cl}=\text{NCF}(\text{CF}_3)_2$. The literature method was used to prepare $\text{LiN}=\text{C}(\text{CF}_3)_2$ (2 mmol) in a rigorously flame-dried 50-mL reaction vessel. The solvent was removed under dynamic vacuum leaving a brown amorphous solid. Onto the solid was condensed $\text{CF}_3\text{SF}_4\text{Cl}$ (3 mmol) at -196 °C and the vessel was warmed slowly to ambient temperature. After 24 h volatile products were separated by trap-to-trap distillation, and $\text{CF}_3\text{SF}_2\text{Cl}=\text{NCF}(\text{CF}_3)_2$ (1.6 mmol) was obtained. The other product isolated was $\text{CF}_3\text{SCl}[\text{NCF}(\text{CF}_3)_2]$ (0.1 mmol).

$\text{CF}_3\text{SF}_2\text{Cl}=\text{NCF}(\text{CF}_3)_2$ is a liquid with a boiling point of 129 °C obtained from the equation $\log P_{\text{Torr}} = 7.78 - 1970/T$. The molar heat of vaporization is 9.0 kcal and the Trouton constant is 22.4 eu.

The ^{19}F NMR spectrum contains resonances at ϕ 143.5, 80.2, 71.9, and -111.8 in the ratio 1.6:3:2, respectively. The resonance at ϕ 143.5, assigned to the isopropyl fluorine is split by two CF_3 groups on carbon ($J_{\text{F-CF}_3\text{C}} = 3.0$ Hz), CF_3 group on sulfur ($J_{\text{F-CF}_3\text{S}} = 0.5$ Hz), and SF_2 ($J_{\text{F-SF}_2} = 9.0$ Hz). The resonance at ϕ 80.2 is assigned to the CF_3 groups on carbon. At ϕ 71.9, the resonance of the CF_3 group on sulfur is split by the SF_2 group ($J_{\text{CF}_3\text{S-SF}_2} = 21$ Hz) and the isopropyl fluorine. The infrared spectrum is as follows: 1418 m, 1275–1245 vs, 1131 s, 1091 ms, 1052 w, 1020 ms, 988 s, 863 ms, 796 m, 764 w, 726 ms, 677 ms, 480 cm^{-1} w.

Anal. Calcd for $\text{C}_4\text{N}_2\text{SClF}_{12}$: C, 13.44; N, 3.92. Found: C, 13.31; N, 4.08.

Preparation of $\text{CF}_3\text{SCl}[\text{NCF}(\text{CF}_3)_2]$. $\text{CF}_3\text{SF}_2\text{Cl}=\text{NCF}(\text{CF}_3)_2$ (2 mmol) was condensed onto $\text{LiN}=\text{C}(\text{CF}_3)_2$ (2 mmol) at -196 °C and then warmed slowly to ambient temperature. After 24 h, the product was separated by trap-to-trap distillation. A higher yield of $\text{CF}_3\text{SCl}[\text{NCF}(\text{CF}_3)_2]$ (1.7 mmol) was obtained than when $\text{CF}_3\text{SF}_4\text{Cl}$ was the starting material. This compound is a colorless liquid with a boiling point of 194 °C from the equation $\log P_{\text{Torr}} = 7.21 - 2022/T$. The molar heat of vaporization is 9.3 kcal and the Trouton constant is 19.8 eu.

The ^{19}F NMR spectrum shows resonances at ϕ 144.6, 79.2, and 73.9 in the ratio 2:12:3. That at ϕ 144.6 is assigned to the isopropyl fluorine and is an overlapping heptet of doublets split by the CF_3 groups on carbon ($J_{\text{F-CF}_3\text{C}} = 4.0$ Hz) and the CF_3 group on sulfur ($J_{\text{F-CF}_3\text{S}} = 0.7$ Hz). The infrared spectrum is as follows: 1336 ms, 1250 s, 1210 s, 1161 s, 1130 s, 1028 m, 994 s, 867 s, 800 ms, 753 m, 748 m, 690 s, 489 cm^{-1} w.

Anal. Calcd for $\text{C}_7\text{N}_2\text{SClF}_{17}$: C, 16.73; N, 5.57. Found: C, 16.49; N, 5.69.

Preparation of $\text{CF}_3\text{S}(\text{NCH}_3)_2\text{N}=\text{C}(\text{CF}_3)_2$. Monomethylamine (10 mmol) and $\text{CF}_3\text{SF}_2\text{Cl}=\text{NCF}(\text{CF}_3)_2$ (2 mmol) were condensed onto a glass vessel equipped with a Teflon stopcock. The reaction mixture was allowed to warm to 25 °C. After 10 h, $\text{CF}_3\text{S}(\text{NCH}_3)_2\text{N}=\text{C}(\text{CF}_3)_2$ (1 mmol) was obtained following trap-to-trap distillation. This compound is a liquid with a boiling point of 153 °C from the equation $\log P_{\text{Torr}} = 6.89 - 1710/T$. The molar heat of vaporization is 7.8 kcal and the Trouton constant is 18.4 eu.

The ^{19}F NMR spectrum shows resonance peaks at ϕ 74.6 and 65.2, assigned to the CF_3 groups on carbon, and a singlet at ϕ 52.9 for the CF_3 group on sulfur. The ^1H NMR shows a singlet signal at $\tau 8.00$. The infrared spectrum is as follows: 2965 m, 1408 ms, 1318 ms, 1267 s, 1210 vs, 1187 m, 1168 m, 1140 s, 931 s, 778 m, 711 m, 488 cm^{-1} w.

Anal. Calcd for $\text{C}_6\text{H}_6\text{N}_3\text{SF}_9$: C, 22.30; H, 1.87; N, 13.00. Found: C, 22.51; H, 2.39; N, 12.66.

Preparation of $\text{SF}_3\text{Cl}=\text{NCF}(\text{CF}_3)_2$. SF_5Cl (7 mmol) was condensed at -196 °C onto a glass vessel which contained $\text{LiN}=\text{C}(\text{CF}_3)_2$ (5 mmol), and allowed to warm to 25 °C. After 24 h the product was recovered from the bath at -98 °C and $\text{SF}_3\text{Cl}=\text{NCF}(\text{CF}_3)_2$ (3.7 mmol) was also obtained at -78 °C. This compound is a colorless liquid with a boiling point of 118 °C from the equation $\log P_{\text{Torr}} = 7.34 - 1747/T$. The molar heat of vaporization is 8.0 kcal and the Trouton constant is 20.4 eu.

The ^{19}F NMR spectrum shows resonances at ϕ 143.9, 81.0, -59.5 , and -120.0 in the ratio 1:6:1:2, respectively. The resonance at ϕ 143.9, assigned to the isopropyl fluorine, is split by all other fluorines in the molecule ($J_{\text{F-CF}_3\text{C}} = 3.1$ Hz, $J_{\text{F-SF}_{\text{ax}}}$ = 13 Hz, $J_{\text{F-SF}_{\text{eq}}}$ = 8 Hz). At ϕ -59.5 , the S-F axial fluorine gives an overlapping triplet of doublets from splitting by two equatorial fluorines on sulfur ($J_{\text{SF}_{\text{ax}}-\text{SF}_{\text{eq}}} = 128$ Hz) and isopropyl fluorine. The S-F equatorial resonance at ϕ -120.0 is a doublet of doublets.

The infrared spectrum is as follows: 1414 ms, 1321 s, 1310 s, 1250 vs, 1208 s, 1125 ms, 1042 m, 990 s, 775 m, 752 ms, 731 ms, 707 ms, 443 cm^{-1} w.

Anal. Calcd for $\text{C}_3\text{NSClF}_{10}$: C, 11.72; N, 4.56. Found: C, 11.82; N, 4.62.

Preparation of $\text{SFCl}[\text{NCF}(\text{CF}_3)_2]$. $\text{SF}_3\text{Cl}=\text{NCF}(\text{CF}_3)_2$ (2 mmol) was condensed onto $\text{LiN}=\text{C}(\text{CF}_3)_2$ (1.5 mmol) at -196 °C and warmed to 25 °C. After 24 h, the product was separated by distillation. $\text{SFCl}[\text{NCF}(\text{CF}_3)_2]$ (1.3 mmol) was obtained. This compound is a colorless liquid having a boiling point of 185 °C from the equation $\log P_{\text{Torr}} = 7.13 - 1945/T$. The molar heat of vaporization is 8.9 kcal and the Trouton constant is 19.5 eu.

The ^{19}F NMR spectrum shows resonances at ϕ 143.6, 74.1, and -71.6 in the ratio 2:12:1, respectively. The resonance at ϕ 143.6, assigned to the isopropyl fluorine, is a doublet of heptets split by the S-F fluorine ($J_{\text{F-SF}} = 7.6$ Hz) and the CF_3 groups on carbon ($J_{\text{F-CF}_3\text{C}} = 4.0$ Hz). The resonances at ϕ 74.1 and -71.6 are assigned to the CF_3 group and SF, respectively.

The infrared spectrum is as follows: 1315 ms, 1260 vs, 1238 s, 1206 s, 1084 m, 1042 ms, 991 s, 952 ms, 755 w, 735 ms, 718 m, 682 m, 542 w, 518 cm^{-1} w.

Anal. Calcd for $\text{C}_6\text{N}_2\text{SClF}_{15}$: C, 15.92; N, 6.19. Found: C, 16.01; N, 6.09.

Preparation of $\text{SF}_3\text{Br}=\text{NCF}(\text{CF}_3)_2$. SF_5Br (5 mmol) was condensed at -196 °C into a glass vessel, equipped with a Teflon stopcock, which contained $\text{LiN}=\text{C}(\text{CF}_3)_2$ (3 mmol). The reactants were allowed to warm to 25 °C. After 24 h unreacted SF_5Br was recovered by trap-to-trap distillation and $\text{SF}_3\text{Br}=\text{NCF}(\text{CF}_3)_2$ (2.6 mmol) was collected at -78 °C. It is a pale yellow liquid with a boiling point of 121 °C from the equation $\log P_{\text{Torr}} = 7.56 - 1844/T$. The molar heat of vaporization is 8.4 kcal and the Trouton constant is 21.4 eu.

The ^{19}F NMR spectrum contains resonances at ϕ 144.3, 81.5, -59.5 , and -139.5 in the ratio 1:6:1:2, respectively. The resonance at ϕ 144.3 is assigned to the isopropyl fluorine, that at ϕ -59.5 to the axial fluorine, that at ϕ 81.5 to CF_3 , and that at -139.5 to the SF equatorial fluorine ($J_{\text{S-F}_{\text{ax}}-\text{SF}_{\text{eq}}} = 125$ Hz; $J_{\text{SF}_{\text{ax}}-\text{CF}}$ = 12.6 Hz; $J_{\text{SF}_{\text{eq}}-\text{CF}}$ = 8.1 Hz; $J_{\text{CF-CF}_3}$ = 3.7 Hz).

The infrared spectrum is as follows: 1413 ms, 1310 s, 1251 s, 1208 s, 1124 ms, 1042 m, 1021 w, 988 s, 777 m, 755 ms, 733 ms, 708 ms, 670 m, 580 w, 548 cm^{-1} w.

Anal. Calcd for $\text{C}_3\text{NSBrF}_{10}$: C, 10.24; N, 3.98. Found: C, 10.54; N, 4.11.

Preparation of $\text{SFBr}[\text{NCF}(\text{CF}_3)_2]$. $\text{SF}_3\text{Br}=\text{NCF}(\text{CF}_3)_2$ (3 mmol) was condensed onto $\text{LiN}=\text{C}(\text{CF}_3)_2$ (2 mmol) at -196 °C and warmed to 25 °C. After 24 h the product was separated by trap-to-trap distillation and $\text{SFBr}[\text{NCF}(\text{CF}_3)_2]$ (1.7 mmol) was obtained. This compound is a liquid with a boiling point of 203 °C from the equation $\log P_{\text{Torr}} = 7.38 - 2142/T$. The molar heat of vaporization is 9.8 kcal and the Trouton constant is 20.6 eu.

The ^{19}F NMR spectrum shows resonances at ϕ 144.9, 74.4, and -91.5 in the ratio 2:12:1, respectively. That at ϕ 144.9, assigned to the isopropyl fluorine, is a doublet of heptets split by both C-F and CF_3 groups ($J_{\text{F-SF}} = 7.4$ Hz; $J_{\text{F-CF}_3\text{C}} = 3.8$ Hz). The resonances at ϕ 74.4 and -91.5 are assigned to the CF_3 and SF groups, respectively.

The infrared spectrum is as follows: 1313 ms, 1265–1240 vs, 1121 w, 1085 m, 1042 w, 1021 m, 989 s, 952 m, 933 w, 821 w, 735 ms, 684 w, 545 cm^{-1} w.

Anal. Calcd for $C_6N_2SBrF_{15}$: C, 14.50; N, 5.64. Found: C, 14.69; N, 5.50.

Acknowledgment is made to the donors of the Petroleum Research Fund, administered by the American Chemical Society, and to the National Science Foundation for support of this research. Mr. S. Krueger and Mr. J. Gruber are thanked for high resolution ^{19}F NMR spectra and mass spectra of solid materials.

References

- (1) H. L. Roberts, *Q. Rev., Chem. Soc.*, **15**, 30 (1961).
- (2) C. Brown, *Sulfur Org. Inorg. Chem.*, **3**, 275 (1972).
- (3) S. P. von Halasz and O. Glemser, *Chem. Ber.*, **103**, 594 (1970).
- (4) S.-L. Yu and J. M. Shreeve, *Inorg. Chem.*, **15**, 14 (1976).
- (5) S.-L. Yu, D. T. Sauer, and J. M. Shreeve, *Inorg. Chem.*, **13**, 484 (1974).
- (6) S. D. Morse and J. M. Shreeve, *Inorg. Chem.*, **16**, 33 (1977).
- (7) R. F. Swindell and J. M. Shreeve, *J. Am. Chem. Soc.*, **94**, 5713 (1972).
- (8) R. F. Swindell, D. P. Babb, T. J. Ouellette, and J. M. Shreeve, *Inorg. Chem.*, **11**, 242 (1972).
- (9) J. A. Gibson and R. Schmutzler, *Z. Anorg. Allg. Chem.*, **416**, 222 (1975).
- (10) C. J. W. Fraser, M. E. McCartney, D. W. A. Sharp, and J. M. Winfield, *J. Inorg. Nucl. Chem.*, **34**, 1455 (1972).
- (11) N. H. Ray, J. R. Case, and H. L. Roberts, *J. Chem. Soc.*, **2066**, 2070 (1961).
- (12) R. E. Banks, R. N. Haszeldine, and W. D. Morton, *J. Chem. Soc. C*, **1947** (1969).
- (13) H. W. Sidebottom, J. M. Tedder, and J. C. Walton, *Trans. Faraday Soc.*, **65**, 2103 (1969).
- (14) F. W. Hoover and D. D. Coffman, *J. Org. Chem.*, **29**, 3567 (1964).
- (15) R. A. Bekker, B. L. Dyatkin, and I. L. Knunyants, *Izv. Akad. Nauk SSSR, Ser. Khim.*, 2738 (1970); *Chem. Abstr.*, **74**, 99366 (1971).
- (16) D. D. Moldavskii and V. G. Temchenko, *Zh. Org. Khim.*, **6**, 185 (1970); *Chem. Abstr.*, **72**, 89678 (1970).
- (17) A. D. Berry and W. B. Fox, *J. Fluorine Chem.*, **6**, 175 (1975).
- (18) A. D. Berry and W. B. Fox, *J. Fluorine Chem.*, **7**, 449 (1976).
- (19) J. Steward, L. Kegley, H. White, and G. L. Gard, *J. Org. Chem.*, **34**, 760 (1969).
- (20) R. D. W. Kemmitt, R. D. Peacock, and J. Stocks, *J. Chem. Soc. D*, 554 (1969).
- (21) J. I. Darragh, G. Haran, and D. W. A. Sharp, *J. Chem. Soc., Dalton Trans.*, 2289 (1973).
- (22) S.-L. Yu and J. M. Shreeve, *J. Fluorine Chem.*, **7**, 85 (1976).
- (23) C. J. Schack, R. D. Wilson, and M. G. Warner, *Chem. Commun.*, 1110 (1969).
- (24) T. A. Kovacina, A. D. Berry, and W. B. Fox, *J. Fluorine Chem.*, **7**, 430 (1976).
- (25) D. T. Sauer and J. M. Shreeve, *Inorg. Chem.*, **10**, 358 (1971).
- (26) R. N. Haszeldine and J. M. Kidd, *J. Chem. Soc.*, **3439** (1959).

Reversible Linkage Isomerisms of β -Diketonato Ligands, Oxygen-Bonded and Carbon-Bonded Structures in Gold(III) Acetylacetonate Complexes Induced by Phosphines

S. Komiya and J. K. Kochi*

Contribution from the Department of Chemistry, Indiana University, Bloomington, Indiana 47401. Received November 23, 1976

Abstract: Dimethylgold(III) complexes provide a unique opportunity to examine in one system the various linkage isomerisms which are possible with β -diketonato ligands. For example, the reversible rearrangement of an acetylacetonato (acac) ligand from a bidentate O-bonded structure in dimethyl(acetylacetonato)gold(III) to a unidentate C-bonded adduct, dimethyl(acetylacetonato)phosphinegold(III), is induced by phosphines. Rearrangement is promoted by donor phosphines in the order $L = PMe_2Ph > PMePh_2 > PPh_3$. Similarly, with a series of para-substituted triphenylphosphines the formation constants ($\log K$) follow a Hammett correlation with $\rho = -1.6$. The temperature dependence of K yields the thermodynamic parameters, $\Delta H = -11 \text{ kcal mol}^{-1}$ and $\Delta S = -35 \text{ cal deg}^{-1}$, which are consistent with the associative interaction for triphenylphosphine. The efficacy of PMe_2Ph allows a crystalline C-bonded adduct, *cis*-(CH_3)₂(acac)Au PMe_2Ph , to be isolated and characterized. By employing the unsymmetrical benzoylacetonato (ba) ligand, two dynamic processes can be observed separately with (CH_3)₂(ba)Au and L by selective line broadening in the NMR spectra. Associative exchange of phosphine leading to a pre-equilibrium (site-interchange) isomerization of the O-bonded ligand occurs rapidly via a five-coordinate intermediate (CH_3)₂(ba)AuL followed by the slower rearrangement to the four-coordinate C-bonded isomer. The observation of a unidentate O-bonded adduct (CH_3)₂(acac)AuL with $L = \text{tricyclohexylphosphine}$ suggests that steric factors play an important role in the rearrangement from O-acac to C-acac. Trifluoro- and hexafluoroacetylacetonato complexes of dimethylgold(III) are cleaved by phosphines to afford cationic gold species, $Me_2AuL_2^+X^-$ (where $X = CF_3COCHCOCH_3, CF_3COCHCOF_3$). Cleavage of β -diketonates can also be effected by hydrochloric acid and water in both the O-acac and C-acac complexes of dimethylgold(III). Prior to hydrolysis, a rapid and specific isotopic exchange is observed between D_2O and only the methine proton in the C-bonded (CH_3)₂(acac)Au PMe_2Ph .

The widely used β -diketone ligands such as acetylacetonone are capable of multiple types of bonding to metals.¹ Acetylacetonato (acac) ligand acting as a bidentate chelate through both oxygen atoms is the most common, but various metal complexes in which a unidentate acac is linked via carbon 3 have been described.² However, there are only a few examples of the interconversion of O-bonded and C-bonded acac complexes. Thus, bis(1,1,1,2,2,3,3-heptafluoro-7,7-dimethyl-4,6-octanedion-5-yl)mercury, (fod)₂Hg, in which the central carbon atoms of both fod ligands are initially linked to mercury, has been found by dynamic NMR spectroscopy to undergo stereospecific intramolecular keto-enol tautomerism

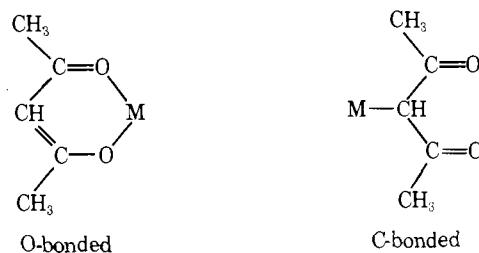

to the carbonyl O-bonded isomer in acetone-*d*₆ solutions.³ Rearrangement of one of the O-bonded acac ligands in Pd(a-